

Compuload LCFS

Load Cell Forklift Scale

- Durable and rugged carriage mounted load cell scale system.
- Accurate to within 0.10%.
- Can be adapted to almost any scale display.
- Fits any brand of forklift /lifting apparatus with standard class II, III and IV carriages.
- Wireless communications options.
- 1kg systems up to 2500kg.
- 100% zero /tare for decanting.
- Compuload LCFS has undergone extensive shock and impact load testing (in accordance with ASTM D642) at an internationally recognized testing facility. Tests show that the weighing units can withstand a head on impact of more than 10 times maximum weighing capacity without affecting its performance.

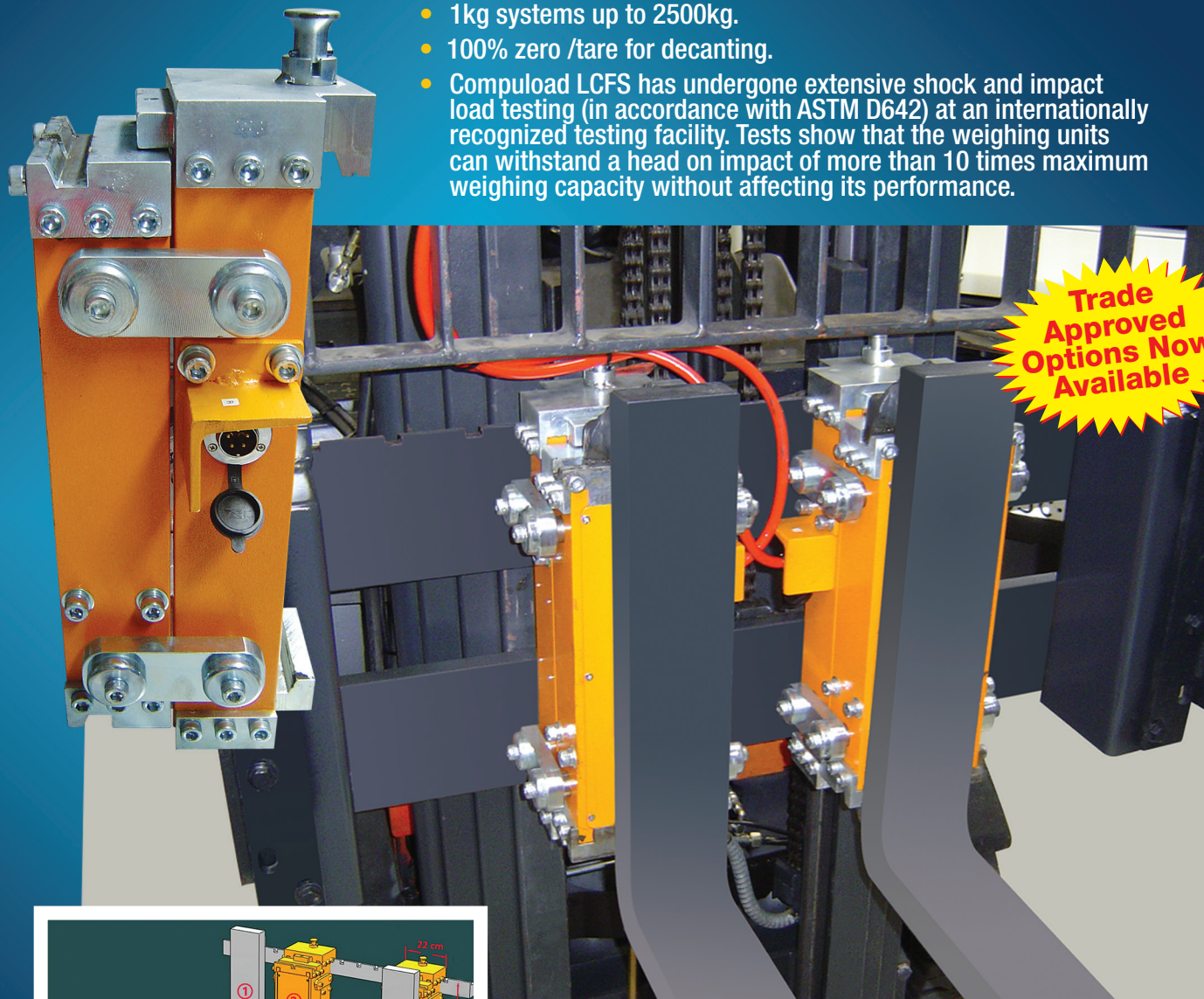

**Trade
Approved
Options Now
Available**

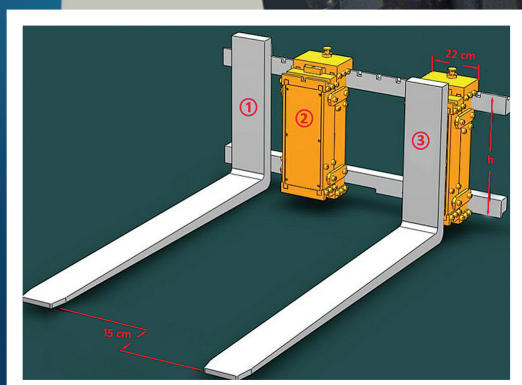

1800 285 277